

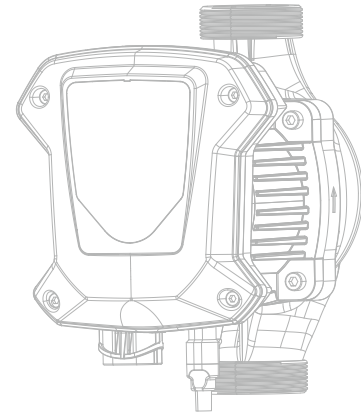

**GB** USER'S MANUAL  
CIRCULATION PUMP



ALTAL Grup Srl  
Chishinau, Moldova, [www.altal.md](http://www.altal.md)  
+37360104125

## High energy efficiency variable speed circulation pump

Read this manual carefully before installation. The product can not be used for medical industry which have the potential to cause personal injury, also can not be used for pumping other liquids than water.



# CONTENT

General information	1
Low-energy circulation pump	1
Pump liquid	1
Connotation of the Type	2
Control panel	GEB32-8-180N 2
Relation between pump setting and pump performance	4
Fault in finding chart	6
Product Installation	8
Insulation foam	9
Dimension	10
Maintenance	11
Warranty Terms	11

## 1 General information

These Operating instructions explain the functions and operation of the pump when installed and ready for use.

The figures referred to in the text can be found on the fold-out plate at the front

## 2 Low-energy circulation pump

Low-energy circulation pump is designed for the circulation of water in heating systems. Install the low-energy circulation pumps in

- Underfloor heating systems
- One-pipe systems
- Two-pipe systems

Low-energy circulation pump incorporates a permanent-magnet motor and difference-pressure control enabling continuous adjustment of the pump performance to the actual requirements

### 2.1 Advantages of installing a Low-energy circulation pump

The installation of a Low-energy circulation pump means

#### Easy installation and start-up

- Low-energy circulation pumps is easy to instal.

With the factory setting , the pump can , in most cases , be started Without marking any setting

#### High degree of comfort

- Minimum noise from valves . etc.

#### Low energy consumption

- Low energy consumption compared to the convention circulation pumps

It is A-labelled as follows



EEI ≤ 0.23

## 3 Pump liquid

Clean , thin , non-aggressive and non-explosive liquids , not containing solid particles , fibres or mineral oil

In heating systems , the water meet the requirements of accepted standards on water quality in heating system

## 4 Connotation of the Type

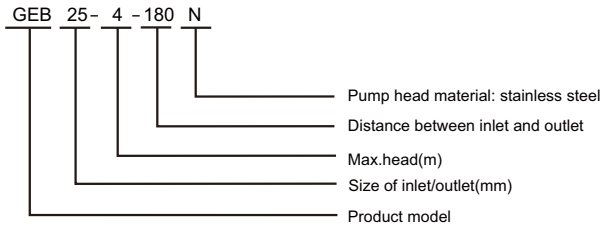

## 5 Control panel

### 5.1 Elements on the control panel



NO	Name
1	Product certification mark
2	PWM functions
3	Indicators for each gear The three lights represent different operating conditions and can be switched between two modes (constant pressure and proportional pressure). When the mode indicator is not illuminated and only the gear indicator is illuminated, this means that it is in fixed speed mode.
4	Power indicator
5	Night mode start/stop
6	PWM function switch
7	AUTO mode indicator
8	Proportional pressure mode indicator
9	Constant pressure mode indicator
10	Night mode indicator
11	Setting button This button is used to switch between modes and gears

### 5.2 Lights fields indicating the pumps setting

Low-energy circulation pump has seven optional setting which can be selected with the push-button . See 8 in the above label  
The pump setting is indicated by seven different light fields . See the above labe





### 5.3 Push-button for selection of pump setting

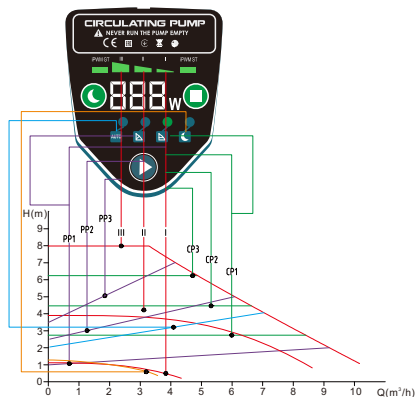

Every time the push-button is pressed , the pump setting is changed  
A cycle is seven button presses

## 6 Relation between pump setting and pump performance

### 6.1 Basic Mode Introduction



Control Panel Pump Curve	Description
 CP1,CP2,CP3	The Operating Point moves back and forth on the curve according to the volume of flow from the system . As shown in the graph , the pump pressure remains constant , not affected by the volume demands of flow
 PP1,PP2,PP3	The Operating Point moves back and forth on the Proportional Pressure curve according to the volume of flow from system . As shown in the graph . the pump pressure is directly proportional to the flow demands
 I II III	In fixed speed mode, three pump motor speeds can be preset according to the specific pump system, SPD1, SPD2 and SPD3, which are characterised by the pump operating at a predetermined constant speed curve.
 AUTO	In adaptive mode, the optimal proportional pressure curve (shaded part) is selected based on the system operating data collected over a period of time, which is used to analyse the current demand on the system.

Control Panel Pump Curve	Description
 Night mode	The pump is changed to an automatic deceleration curve at night, so that it runs at low performance and low power consumption
 iPWM GT	PWM EXTERNAL SPEED CONTROL(optional) (See 6.2 for details)
 iPWM ST	PWM EXTERNAL SPEED CONTROL(optional) (See 6.2 for details)

### 6.2 PWM Description

#### 6.2.1 Control principle

When PWM signal is connected, the operation of circulating pump is controlled by PWM signal, If there is no PWM signal, the operation of circulating pump is controlled by internal control logic.

#### 6.2.2 iPWM GT

At high PWM signal percentages (duty cycles), a hysteresis prevents the circulating pump from starting and stopping if the input signal fluctuates around the shifting point. At low PWM signal percentages, the circulating pump speed is high for safety reasons. In case of a cable breakage in a gas boiler system, the circulating pump will continue to run at maximum speed to transfer heat from the primary heat exchanger. This is also suitable for heat circulating pumps to ensure that the circulating pump can transfer heat in case of a cable breakage

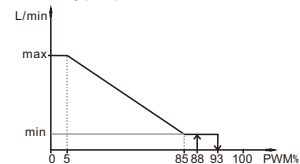

PWM input signal (%)	Pump status
$0 \leq \text{PWM} \leq 5$	Maximum speed: Max.
$5 < \text{PWM} \leq 85$	Variable speed: max. to min.
$85 < \text{PWM} \leq 93$	Minimum speed: Min
$85 < \text{PWM} \leq 88$	Hysteresis area: on/off
$94 < \text{PWM} \leq 100$	Standby mode: off

### 6.2.3 iPWM ST

At low PWM signal percentages ( duty cycles ) , a hysteresis prevents the circulating pump from starting and stopping if the input signal fluctuates around the shifting point Without PWM signal percentages , the circulating pump will stop for safety reasons . If a signal missing , for example due to a cable breakage , the circulating pump will stop avoid overheating of the solar thermal system.

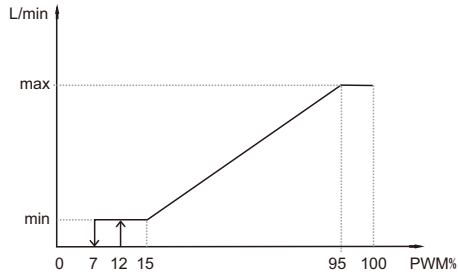

PWM input signal (%)	Pump status
$0 \leq \text{PWM} < 7$	Standby mode: off
$7 \leq \text{PWM} \leq 12$	Hysteresis area: on/off
$12 < \text{PWM} \leq 15$	Minimum speed: Min
$15 < \text{PWM} \leq 95$	Variable speed: min. to max.
$95 < \text{PWM} \leq 100$	Maximum speed: Max

## 7 Fault in finding chart



### Warning

Before starting any work on the pump , make sure that the Electricity supply has been switched off and that it cannot be Accidentally switched on

### Outline structure diagram

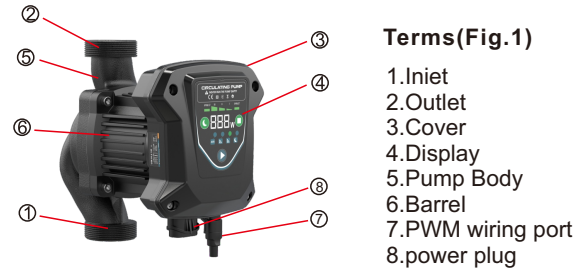

### Terms(Fig.1)

- 1.Inlet
- 2.Outlet
- 3.Cover
- 4.Display
- 5.Pump Body
- 6.Barrel
- 7.PWM wiring port
- 8.power plug

### Internal structure diagram

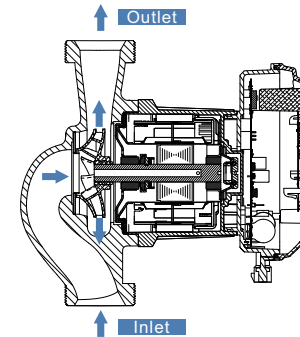

## 8 Product Installation

### 8.1 Installation location

The pump should be installed indoors.

### 8.2 Installation

When installing a circulation pump, the arrow on the pump casing indicates the direction of flow of the liquid through the pump. When installed, the shaft of the electric pump must be horizontal.

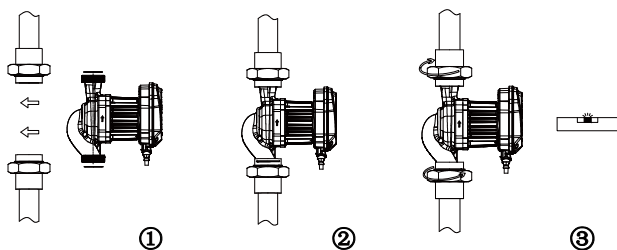

### 8.3 Installation direction

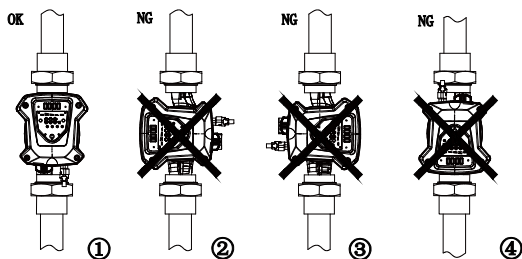

### Warning



The pumped liquid may be high temperature and high pressure. Before removing the socket head cap screws, the liquid in the system must be drained or the valves on both sides of the electric pump must be closed.

### Warning



When changing the position of the junction box, the electric pump can only be started after the system is full of pumped liquid or the valves on both sides of the electric pump are open.

### 8.4 Control box position

Junction box can be rotated within 90°

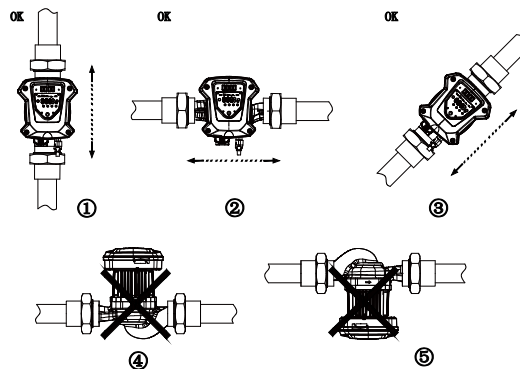

## 9 Insulation foam

### Attention



Limit heat loss from the pump body. Reduce heat loss from the pump by physically isolating the pump casing from the surrounding environment.

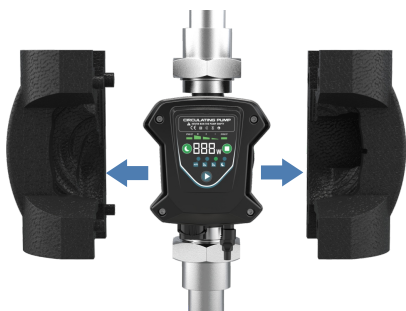

The water pump foam for the heating system is attached with the pump. Before installing the water pump, remove the heat insulating foam, and then put the foam on the pump body after the installation is completed.

## 10 Dimension

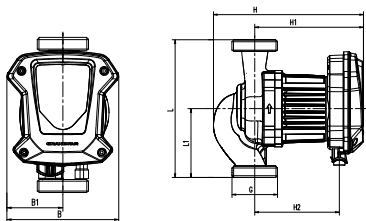

Model	Pump body material		Dimensions(mm)								
	Cast iron	Stainless steel	L	L2	B	B1	H	H1	H2	G	
GEB25-4-180(N)	●	●	180	90	130	65	196	142	110.5	1.5"	
GEB25-6-180(N)	●	●	180	90	130	65	196	142	110.5	1.5"	
GEB25-8-180(N)	●	●	180	90	130	65	196	142	110.5	1.5"	
GEB25-10-180(N)	●	●	180	90	130	65	196	142	110.5	1.5"	
GEB25-12-180(N)	●	●	180	90	130	65	196	142	110.5	1.5"	
GEB32-4-180(N)	●	●	180	90	130	65	196	142	110.5	2"	
GEB32-6-180(N)	●	●	180	90	130	65	196	142	110.5	2"	
GEB32-8-180(N)	●	●	180	90	130	65	196	142	110.5	2"	
GEB32-10-180(N)	●	●	180	90	130	65	196	142	110.5	2"	
GEB32-12-180(N)	●	●	180	90	130	65	196	142	110.5	2"	

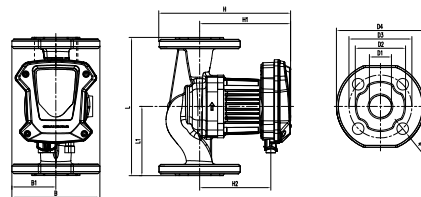

Model	Pump body material		Dimensions(mm)												
	Cast iron	Stainless steel	L	L1	B	B1	H	H1	H2	D1	D2	D3	D4	D5	
GEB32-4-220F(N)	●	●	220	110	140	70	210	145	113	32	80	100	140	19	
GEB32-6-220F(N)	●	●	220	110	140	70	210	145	113	32	80	100	140	19	
GEB32-8-220F(N)	●	●	220	110	140	70	210	145	113	32	80	100	140	19	
GEB32-10-220F(N)	●	●	220	110	140	70	210	145	113	32	80	100	140	19	

## 11 Maintenance

After 2000 hours of normal use, the electric pump should be repaired and maintained according to the following steps:

- (1) Disassembly: Check whether there are knots or foreign objects inside the motor, and clean it up in time if there is.
- (2) Air tightness test: After disassembling the machine to repair or replace various seals, the water (air) pressure test must be carried out on the pump. The test pressure is 0.2Mpa (megapascal), and there should be no leakage and sweating for 3 minutes.
- (3) When the temperature is below 4°C, anti-freeze work should be done to avoid freezing and cracking the pump body.
- (4) If the electric pump is not used for a long time, the pipeline should be removed, the water accumulated in the pump should be drained, the main parts should be scrubbed clean, and rust-proof treatment should be carried out. Place the pump in a dry and ventilated place and keep it properly.

## 12 Warranty Terms

The warranty period of the GEB series canned pump is six months from the date of purchase. During the warranty period, the company will provide free maintenance services for failures that occur under normal use conditions as required by the instruction manual. If the fault is caused by the following conditions, the company needs to carry out paid repairs:

- (1) Failure caused by natural disasters or human factors.
- (2) Failure caused by special use environment.
- (3) Fault caused by incorrect wiring or abnormal power supply.
- (4) Identified by our technicians as a failure caused by abnormal operation or improper use.